

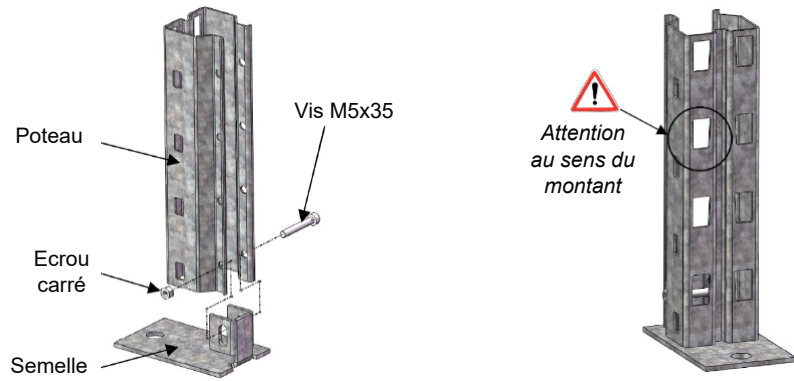

1 Emboîter les semelles métalliques

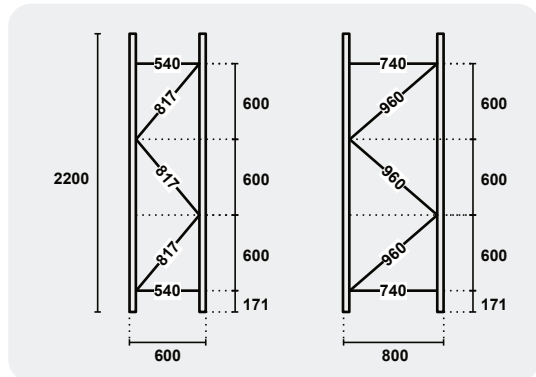

2 Assemblage des échelles

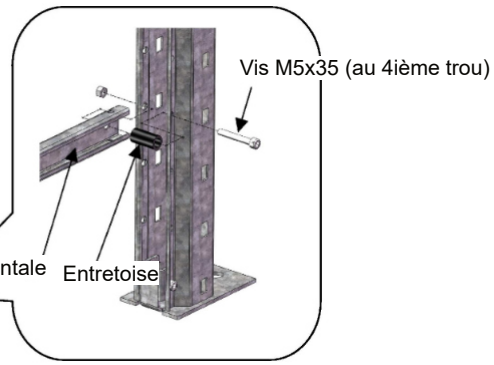
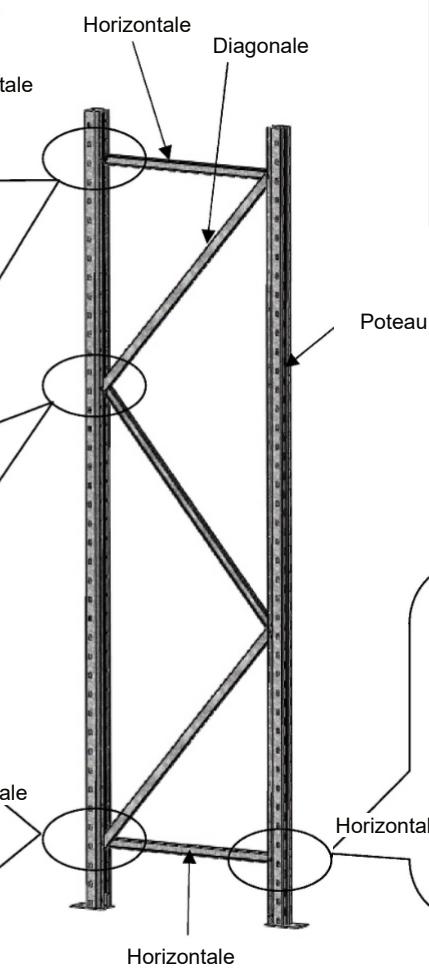
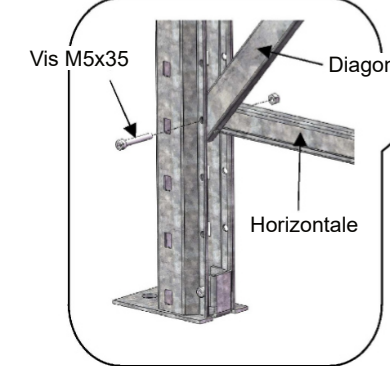
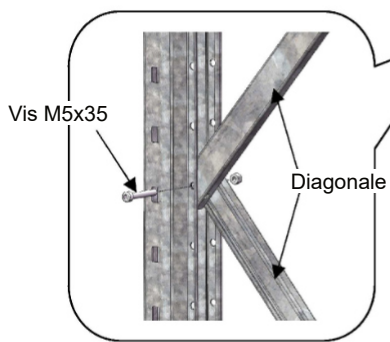
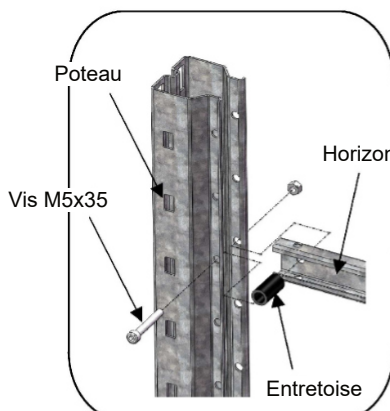



3 Emboîter les longerons

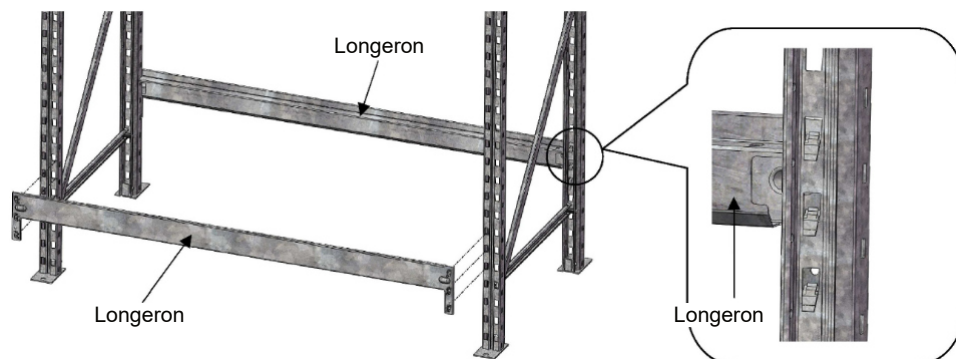

4 Verrouiller les longerons

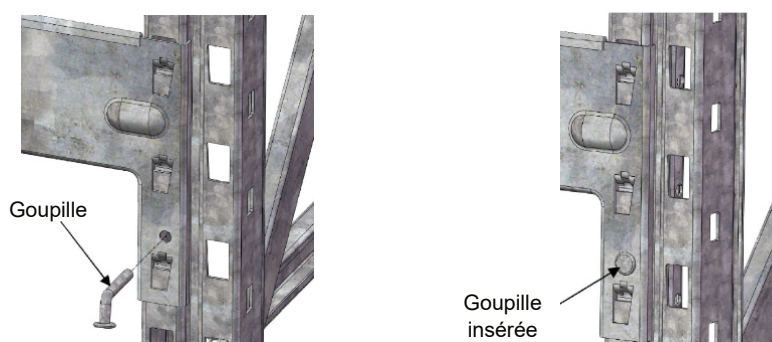

5 Poser les platelages

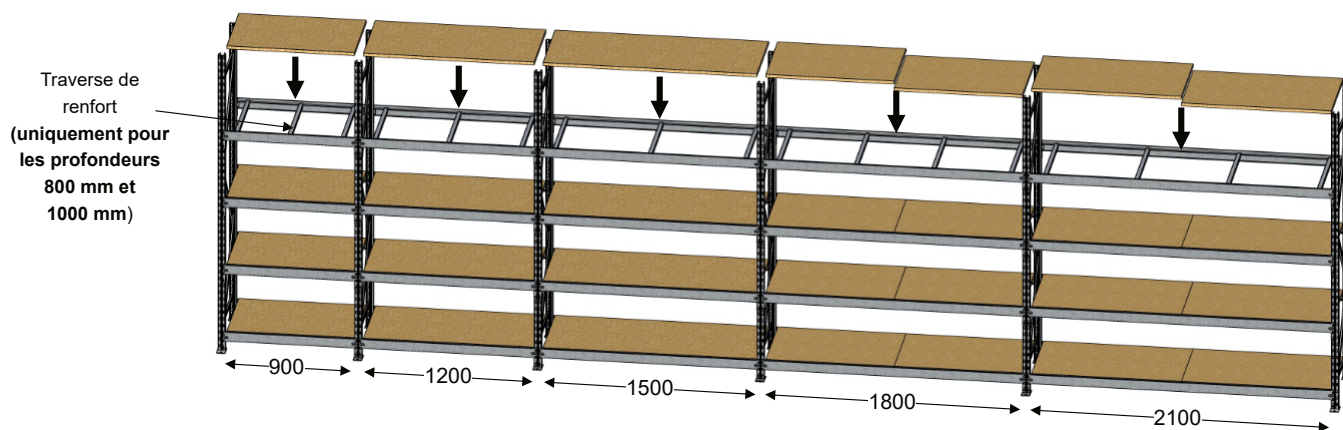

Nombre de traverses par niveau

Longueur (mm)	Profondeur (mm)		
	600	800	1000
900	0 (260 kg*)	3 (220 kg*)	3 (180 kg*)
1200	0 (340 kg*)	3 (220 kg*)	3 (180 kg*)
1500	0 (430 kg*)	3 (220 kg*)	3 (180 kg*)
1800	0 (520 kg*)	4 (340 kg*)	4 (270 kg*)
2100	0 (520 kg*)	4 (340 kg*)	4 (270 kg*)

* Charge uniformément répartie par niveau

Quelques rappels de sécurité :

- Le rayonnage doit impérativement être installé sur un sol plan qui résiste au poinçonnement (sol béton).
- Chargement manuel uniquement (chargement par gerbeur etc., interdit).
- Ne pas modifier la structure ou les éléments du rayonnage.